

www.ep-ep.com

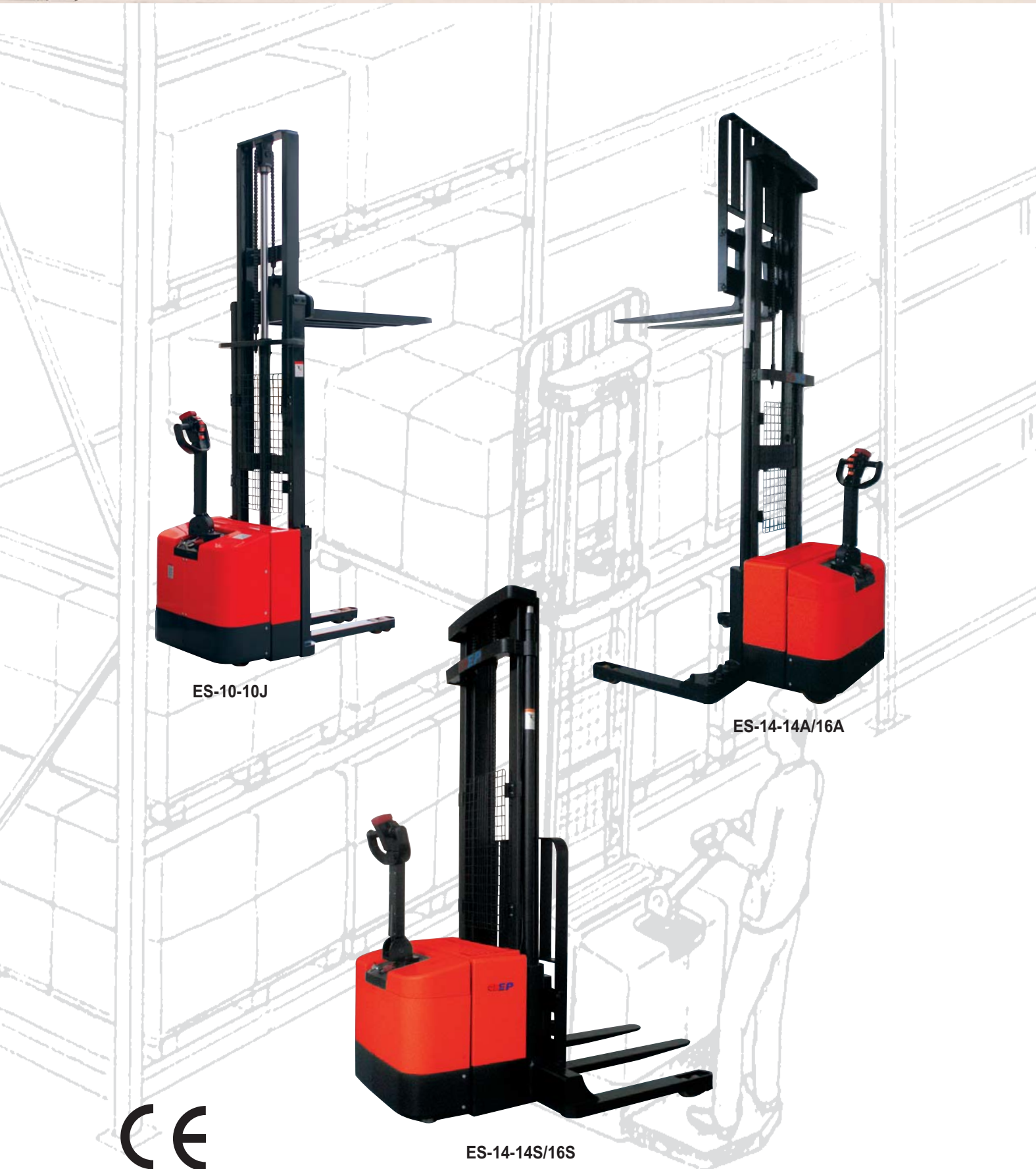

Customization is available
 Products and specifications are
 subject to be changed without notice

Option:

- Lifting height: 3m/3.3m/4m/4.5m
- Adjustable straddle available
- Rider platform
- Industry battery
- Start battery
- Hand set
- Top safe gaurd
- BDI & hour meter

E-P Equipment Co.,LTD

www.ep-ep.com

Let's grow together...
 E-P Equipment is a specialized manufacturer of material handling equipment.

China:
E-P EQUIPMENT CO., LTD
 No. 121 YongHua Street, Shi Qiao Road,
 Xia Cheng Qu Hangzhou, China
 Tel: 86-571-28035676/28035633/28035657/28035653
 Fax: 86-571-28035665
 Email: info@ep-ep.com

USA:
E-P EQUIPMENT, USA CORP.
 1865 E.Main St.
 Suite F, Duncan, SC 29334
 Tel: 1-864-486-8774
 Fax: 1-864-486-8779
 Toll Free: 866-373-8722
 E-mail: info@ep-ep.com

Japan:
E-P EQUIPMENT JAPAN
 #105 2-16-10 Hirao, Inagi-shi
 Tokyo 206-0823 Japan
 Tel: 81-42-3506422
 Fax:81-42-3506423
 E-mail:ep-japan@ep-ep.com

Korea:
E-P EQUIPMENT KOREA
 1058-Ra Dong, Buck Yi-Dong,
 Ilsan/Gu, Koyang/Shi, Kyunggi/Du,
 Korea
 Tel: 82-31-9254100
 Fax:82-31-9254102
 E-mail:ep@ep-ep.co.kr

Electric Stacker



Let's grow together
ISO9001

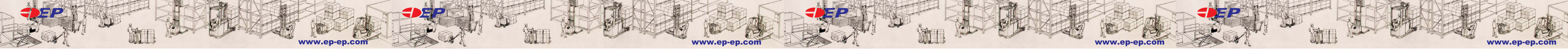

Specifications:

Model			ES-10-10M	ES-10-10J	ES-10-10FL	ES-12-12FL	ES-12-12E	ES-14-14E	
1	Capacity	kg	1000	1000	1000	1200	1200	1400	
2	Characteristics	Load center	600						
3	Operator type	Walkie (rider option)							
4	Maximum lifting height	mm	3000/3300	3000/3300	3000/3300		3000/3300/3600/4000		
5	Lowered height of fork	mm	80						
6	Standard fork width	mm	540						
7	Standard fork length	mm	1150						
8	Fork width	mm	185						
9	Minimum turning radius	mm	1366	1405	1482	1482	1405	1482	
10	Minimum aisle width	mm	2315.5	2702	2780	2780	2702	2780	
11	Minimum ground clearance	mm	30						
12	Maximum travel speed	Laden km/h	3.4	3					
	Unladen km/h		3.9	3.5					
13	Maximum lifting speed	Laden m/s	0.13						
	Unladen m/s		0.23						
14	Maximum lowering speed	Laden m/s	0.13						
	Unladen m/s		0.23						
15	Gradeability	Laden %	5 (within 5min)						
	Unladen %		7 (within 30min)						
16	Weight	Service weight without battery pack (3M standard)	kg	670	839	855	855	839	855
17	Service weight with battery pack (3M standard)	kg	738	1020	1050	1161	1145	1161	
18	Overall length (3M standard)	mm	1665.5	1797	2004	2004	1797	2004	
19	Overall width	mm	800	800	850	850	800	850	
20	Mast extended height	mm	3694	3700	3700		3500/3800/4100/4500		
21	Mast lowered height	mm	2100	2300	2100		2135/2135/2335/2535		
22	Wheel type front/rear	poly/poly							
23	Wheels	1xDriven wheel, 2xUniversal wheel, 4xFront wheel							
24	wheel base	mm	922	1229	1307	1307	1229	1307	
25	Brake	Electromagnetic							
26	Motor	Travelling	24V,0.6kw		24V, 0.93kw				
27	Lifting	24V,2kw		24V, 3kw					
28	Voltage	24V							
29	Battery	Capacity	AH	135	135	135	210	210	280
30	Max battery size (L*W*H)	mm	180*240*370		360*275*172		823*248*610		
31	Control system	CURTIS 1243							

Specifications:

Model			ES-14-14S ES-14-30A	ES-16-16S ES-16-35A
1	Capacity	kg	1400	1600
2	Characteristics	Load center	600	
3	Operator type	Walkie (rider option)		
4	Maximum lifting height	mm	3000/3300/3600/4000	
5	Lowered height of fork	mm	50	
6	Standard fork length	mm	1110	
7	Fork width	mm	100	
8	Minimum turning radius	mm	1482	
9	Minimum aisle width	mm	2780	
10	Minimum ground clearance	mm	30	
11	Maximum travel speed	Laden km/h	3	
	Unladen km/h		3.5	
12	Maximum lifting speed	Laden m/s	0.13	
	Unladen m/s		0.23	
13	Maximum lowering speed	Laden m/s	0.13	
	Unladen m/s		0.23	
14	Gradeability	Laden %	5(within 5min)	
	Unladen %		7(within 30min)	
15	Weight	Service weight without battery pack (3M standard)	kg	844
16	Service weight with battery pack (3M standard)	kg	1150	
17	Overall length (3M standard)	mm	1875	
18	Length	mm	1582	
19	Straddle OD	mm	1470	
20	Straddle ID	mm	1270	
21	Straddle OD (ES-14-14A,ES-16-16A)	mm	1470/1320/1160	
22	Straddle ID (ES-14-14A,ES-16-16A)	mm	1270/1120/960	
23	Mast extended height (3m/3.3m/3.6m/4m)	mm	4198/4498/4798/5198	
24	Mast lowered height (3m/3.3m/3.6m/4m)	mm	2135/2135/2335/2535	
25	Tyre type front/rear	poly/poly		
26	Wheels	1xDriven wheel, 1xUniversal wheel, 4xFront wheel		
27	wheel base	mm	1307	
28	Brake	Electromagnetic		
29	Motor	Travelling	24V, 0.93kw	
30	Lifting	24V, 3kw		
31	Voltage	24V		
32	Battery(suggested)	Capacity	280Ah	
33	Max battery size (L*W*H)	mm	823*248*610	
34	Control system	CURTIS 1243		

Specifications:

Model			ES-14-14EM ES-16-16EM	ES-16-16ET	ES-16-16ST
1	Capacity	kg	1400 / 1600	1600	1600
2	Characteristics	Load center	600		
3	Operator type	Walkie(rider option)			
4	Maximum lifting height	mm	3000/3300/3600/4000	4500	4500
5	Lowered height of fork	mm	90	90	90
6	Standard fork width	mm	540	540	
7	Standard fork length	mm	1150	1150	1110
8	Fork width	mm	185	185	100
9	Minimum turning radius	mm	1482	1512	1512
10	Minimum aisle width	mm	2780	2810	2810
11	Minimum ground clearance	mm	30	30	30
12	Maximum travel speed	Laden km/h	3	3	3
	Unladen km/h		3.5	3.5	3.5
13	Maximum lifting speed	Laden m/s	0.13	0.13	0.13
	Unladen m/s		0.23	0.23	0.23
14	Maximum lowering speed	Laden m/s	0.13	0.13	0.13
	Unladen m/s		0.23	0.23	0.23
15	Gradeability	Laden %	5 (within 5min)	5 (within 5min)	5 (within 5min)
	Unladen %		7 (within 30min)	7 (within 30min)	7 (within 30min)
16	Weight	Service weight without battery pack (3M standard)	kg	855	1251
17	Service weight with battery pack (3M standard)	kg	1161	1557	1577
18	Overall length (3M standard)	mm	1875	1905	1905
19	Overall width	mm	850	850	1470
20	Mast extended height	mm	3500/3800/4100/4500	5180	5180
21	Mast lowered height	mm	2135/2135/2335/2535	2135	2135
22	Wheel type front/rear	poly/poly			
23	Wheels	1xDriven wheel,2xUniversal wheel 4xFront wheel			
24	wheel base	mm	1307	1367	1357
25	Brake	Electromagnetic			
26	Motor	Travelling	24v,0.93kw	24v,2.2kw	24v,2.2kw
27	Lifting	24v,3kw			
28	Voltage	24v			
29	Battery	Capacity	280AH		
30	Max battery size (L*W*H)	mm	648*248*558		
31	Control system	CURTIS 1243			

Specifications:

Model			ES-10-10C
1	Capacity	kg	1000
2	Characteristics	Load center	500
3	Operator type	Walkie(rider option)	
4	Maximum lifting height	mm	3000/3300
5	Ovandar fork width	mm	630
6	Standard fork length	mm	1150
7	Fork thickness	mm	40
8	Fork width	mm	100
9	Minimum turning radius	mm	1300
10	Minimum aisle width	mm	2500
11	Maximum travel speed	Laden mm	3
	Unladen km/h		5
12	Maximum lifting speed	Laden km/h	0.13
	Unladen m/s		0.23
13	Maximum lowering speed	Laden m/s	0.13
	Unladen m/s		0.23
14	Gradeability	Laden m/s	5(within 5min)
	Unladen %		7(within 30min)
15	Mast tilt angle	Backward %	3
	Forward kg		6
16	Weight	Service weight without battery pack (3M standard)	kg
17	Service weight with battery pack (3M standard)	mm	1305
18	Overall length including forks	Platform folded mm	2480
	Unfolded mm		2930
19	Overall width	mm	900
20	Overall rear height	mm	1105
21	Rear body length	mm	1418
22	Rear body width	mm	850
23	Rear body height	mm	885
24	Handle width	mm	430
25	Mast extended height (3m/3.3m)	mm	3815/4115
26	Mast lowered height (3m/3.3m)	mm	2210
27	Wheel type front/rear	poly/poly	
28	Dimension of driven wheel	mm	Ø248*75
29	Dimension of load wheel	mm	Ø160*80
30	Brake	Electromagnetic	
31	Motor	Travelling	1.35kw
32	Lifting	3.0kw	
33	Battery	Voltage	24v
34	Capacity	280AH	
35	Control system	CURTIS 1243	